

LMC MINI-FACER EVO[®]™

Manuel Operated Flange Facer

For re- machining of damaged flange faces

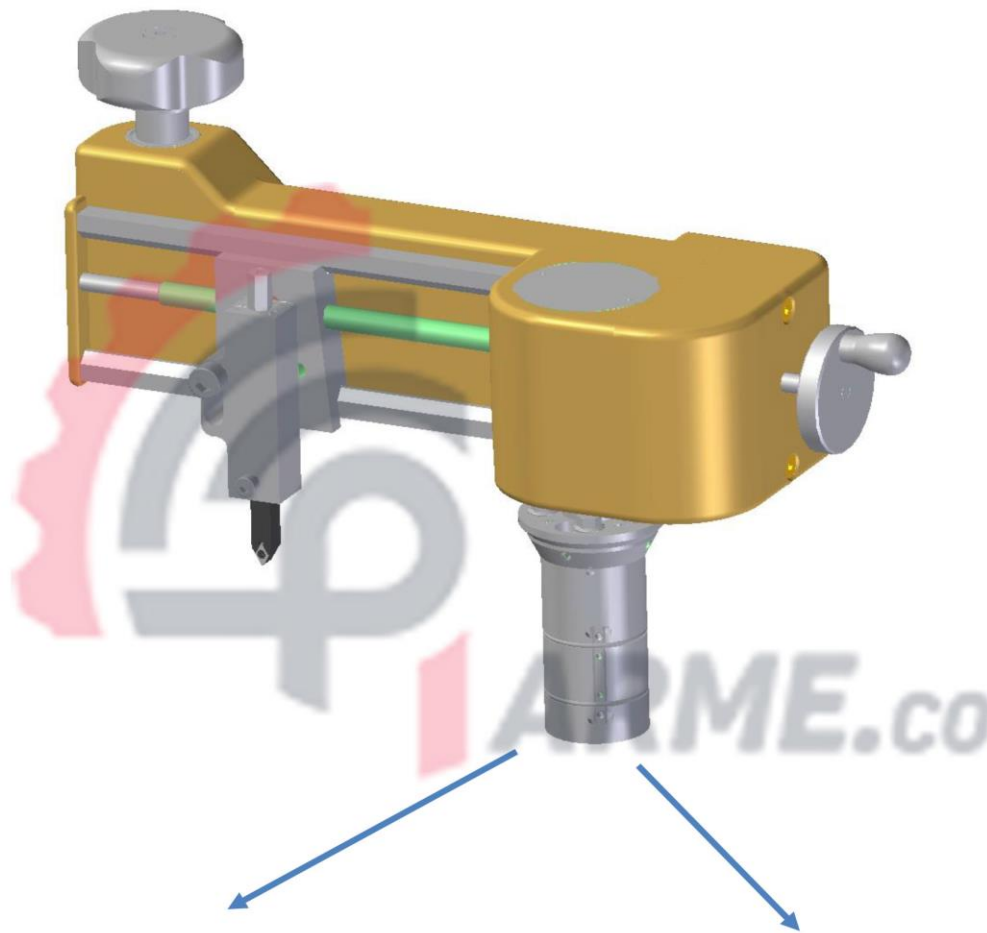

COLLET

BASE



تامین و تجهیز ابزار دقیق آرمه
Armecompany.com
09125795160

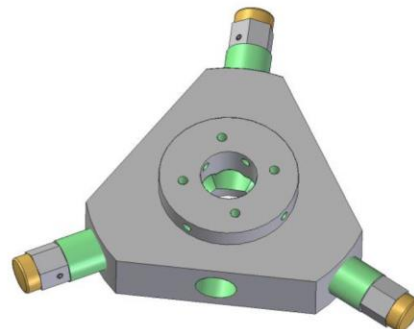

LMC MINI-FACER EVO[®]™

Operational data

Clamping

	Collet	Base
Min int clamp cap	Ø 48,2 mm < 2"	Ø 152 mm < 6"
Max int clamp cap	Ø 240mm > 9"	± Ø 560 mm > 22"

Facing

	Min	Max
Facing diameter	Ø 48,2 mm < 2"	Ø 560 mm > 22"

Type of flanges that can be machined

-RF / T & G

Dimensional data

Weight ready to use: ± 9kg

Minimum swing radius: 292 mm

Achievable surface finish

- Stock finish - ASME B16.5

- Smooth finish

