

# LMC Mini – Facer ©®™

Manual Operated Flange Facer

For re- machining damaged flange faces



تامین و تجهیز ابزار دقیق آرمه  
Armecompany.com  
09125795160

## Operational data

Min int clamp cap :  $\varnothing$  25,4 mm ( 1" )

Max int clam cap :  $\varnothing$ 252 mm (  $\pm$ 10" )

Min facing diam :  $\varnothing$  30 mm :  $\pm$ 1 ¼"

Max facing diam :  $\pm$   $\varnothing$  350 mm : 14"

## Dimentional data :

Weight ready to use : 7 kg ( 15.4 lbs)

Overall length : 320 mm (  $\pm$ 12.5" )

Height from Flange face upward :  $\pm$  200 mm ( 8 " )

Minimum swing diameter :  $\varnothing$  457,2 mm ( 18" )





Delivery consisting off :

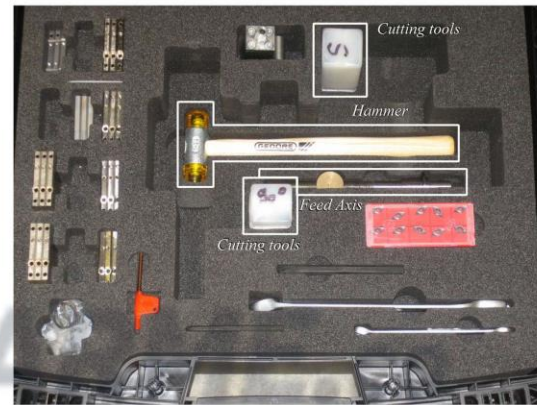

- Complete set of hardened internal grippers
  - Range from 25,4mm ( 1" ) id up to and included 252 mm (±10")
- 2 off ( easy exchangeable ) feed screws ASME 16.5 i.e:
  - 1 off for Smooth finish
  - 1 off for Stock finish
- Sturdy Carry / transport case with compartments for all components
- The Mini Facer <sup>TM</sup>® comes ready to use
- Set off handtools consisting off :
  - Plastic Hammer , allan keys , spanners , toolbit TORX bit
- Cutting tool
  - 1 straight ( neutral ) toolbit holder
  - 1 pc angled 90° toolbit holder
  - Start set of Cutting tips suitable for :
    - Carbon steel ,Stainless steel , aluminium , alloys etc



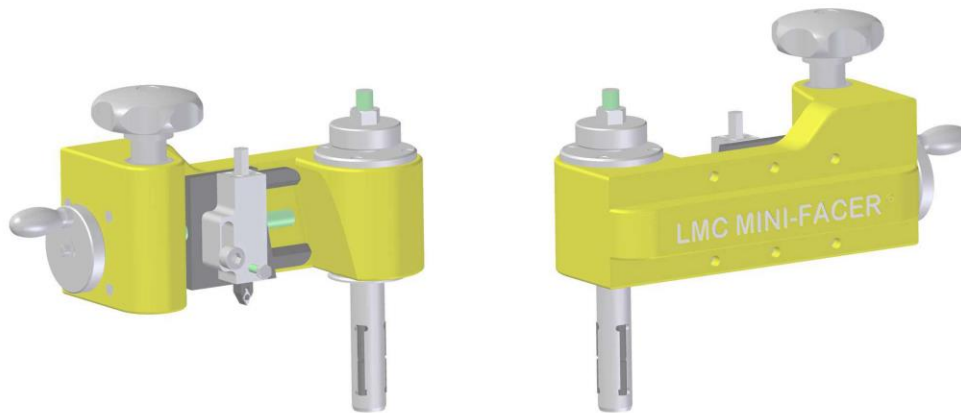

Flange facing made easy with the “ LMC Mini Facer ”

This easy to operate hand held flange facer ,  
allows any technician to recondition RF / FF and other gasket seatings in situ.

The internal diameter that can be clamped , is  $\pm 01$  “ to  $\pm 010$ ” .

Due to clamping and machining range ,  
the Mini Facer is a very efficient tool for service or repair workshop but  
also for piping construction companies and or vessel manufacturers .

Developped and manufactured by :

LenMatec bvba

Ambachtsstraat 7

B 3980 Tessenderlo

Belgium

Tel(+)**32 (0) 13 67 66 90**

Fax (+)**32 (0) 13 67 68 06**



Mail to : [info@lenmatec.be](mailto:info@lenmatec.be)

URL : [WWW.LENMATEC.BE](http://WWW.LENMATEC.BE)



# LMC Mini - Facer ©®™ Dimensions

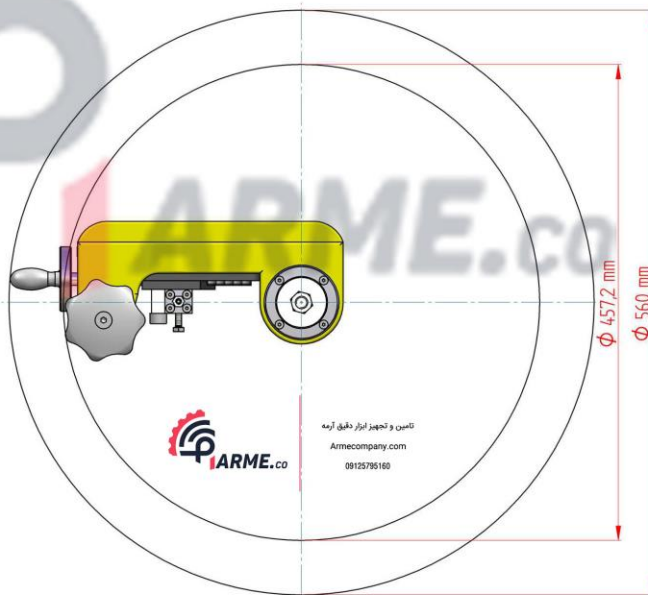
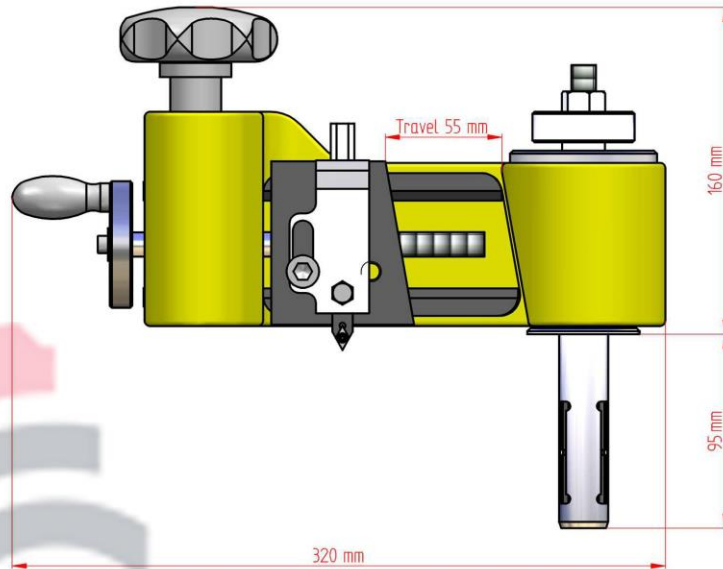

*Len Matec*

