

Model SM4

Allen Rotary-Style Gasket Cutter

Operating Instructions



تامین و تجهیز ابزار دقیق آرمه

Armecompany.com

09125795160

ALLPAX
GASKET CUTTER SYSTEMS

INTRODUCTION

Congratulations! You are the owner of the finest rotary-style gasket cutter in the world. Originally developed and patented in the 1930's, the heavy-duty Allen SM4 Rotary-Style Gasket Cutter is ideal for the custom fabrication of both metallic and non-metallic ring and flange gaskets. Thousands are in use everyday in a wide range of industries including petrochemical plants, shipyards, power plants, breweries, pulp and paper plants, refrigerated facilities, and oil refineries. Easy to operate and virtually maintenance-free, the SM4 will cut perfect gaskets and provide trouble-free operation for years to come.

MODEL SM4 SPECIFICATIONS

Weight:	78 pounds
Configuration:	Recommended for fixed operation
Mounting:	Bench mount
Throat:	8-3/4"
Cutting Diameters:	3"ID to 28"OD with standard scale bar 28"ID to 54"OD with optional scale bar (not included) 54"ID to 80"OD with optional scale bar (not included)
Gasket Width:	1/4" to 8-3/4"
Gasket Thickness (Max):	1/4" (See table for maximum thickness by material)
Recommended Gasket Materials:	Metallic or non-metallic
Top Cutting Disc Installed:	For metallic gasket materials
Top Cutting Disc Spare:	For non-metallic gasket materials
Bottom Cutter Installed:	For both metallic and non-metallic gasket materials

MODEL SM4

Maximum Recommended Material Thickness (Inches)

GASKET MATERIAL	Cutter Set for Non-Metal Part # M429	Cutter Set for Metal Part # M428
Non-Metallic		
Asbestos	0.125	N/R
Cardboard (Flat)	0.250	N/R
Cloth Insert	0.250	N/R
Cork	0.250	N/R
Fiber	0.188	N/R
Kevlar	0.010	N/R
Rubber	0.188	N/R
Teflon	0.125	N/R
Metallic		
Brass	N/R	0.040
Copper	N/R	0.063
Iron (Galvanized)	N/R	0.040
Lead	N/R	0.125
Monel	N/R	0.030
Steel (Soft)	N/R	0.040
Steel (Stainless)	N/R	0.030
Tin	N/R	0.040
Zinc	N/R	0.040



ASSEMBLY

Carefully unpack the unit. For shipping, the scale bar is stored in an inverted position. Loosen the scale bar T-screw and remove the scale bar. Re-insert the scale bar into its proper position and tighten T-screw. The Model SM4 comes pre-adjusted at the factory.

MOUNTING THE UNIT



(Figure 1) Model SM4 is a heavy-duty unit and is typically bolted to the flat surface of a workbench using the four 3/8" diameter holes on the mounting base.



(Figure 2) Proper hand crank rotation as viewed from side.

NOTE: In the instructions that follow, turning the hand crank in the direction of the arrow above is considered clockwise.

OPERATING THE UNIT

Model SM4 is designed to cut both metallic and non-metallic gasket materials. It ships with a factory installed top cutting disc designed for cutting metal gasket materials. A spare top cutting disc designed for cutting non-metal gasket materials is also included and can be installed in the field.

NOTE: The pre-installed bottom cutter will cut both metal and non-metal materials.

Select the sheet gasket material to be cut. Measure the material and cut into a rough square making sure that the shortest side measures larger than the outside diameter (OD) of the gasket to be cut. Trim the corners if necessary.

For metallic gasket materials, punch, or drill, 3/8" guide hole in the approximate center of the trimmed gasket material. For non-metallic gasket materials, punch 1 1/32" guide hole (#13 punch).

NOTE: Punching the exact diameter guide hole ensures that the gasket material stays centered and that the cutter tracks properly.



(Figure 3) Loosen the scale bar T-screw and slide the scale bar to the desired OD setting. Hand tighten the T-screw.

NOTE: Markings on the scale bar designate radius, not diameter.



(Figure 4) Disengage the top cutting disc by rotating the cutting disc lever counter-clockwise.

OPERATING THE UNIT



(Figure 4) Unscrew and remove the scale bar knurled nut from the scale bar assembly.

NOTE: The SM4 scale bar knurled nut incorporates a left-hand thread.

Using the guide hole, position the gasket material onto the threaded scale bar spindle. Screw the knurled nut back onto the spindle to firmly secure the material. Hand tighten.



(Figure 6) To cut the OD, engage the top cutting disc by rotating the cutting disc lever clockwise. The top cutting disc should now penetrate or contact the gasket material and is now in the proper position for cutting.



(Figure 7) Turn the hand crank clockwise. Simultaneously, with the other hand, maintain a constant downward pressure on the cutting disc lever. As the cutting discs rotate, the gasket material will be drawn towards the cutting discs initiating the cutting process. Continue cranking until the entire OD of the gasket material has been cut. Disengage the top cutting disc. Discard unwanted material.

NOTE: Cutting thick and/or tough materials may require more than one revolution through the unit. Flipping the material over and repeating the above process is often advantageous.



(Figure 8) To cut the inner diameter (ID), loosen the scale bar T-screw, and slide the scale bar to the desired setting. Hand tighten the scale bar T-screw. Engage the top cutting disc. Turn the hand crank, simultaneously maintaining downwards pressure on the cutting disc lever as before. Continue cranking until the entire ID of the gasket material has been cut. Disengage the top cutting disc and remove the newly cut gasket. Unscrew and remove knurled nut from spindle. Discard unwanted material.

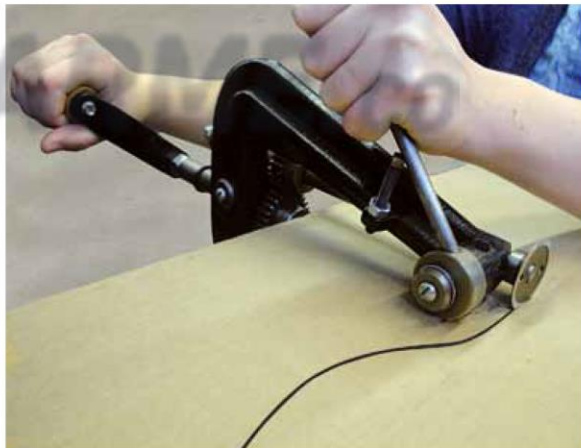

(Figure 9) To cut irregular shaped gaskets, mark the shape desired on the gasket material with a pencil or pen. Loosen the scale bar T-screw. Remove the scale bar, and manually feed the material through the cutters while operating the unit in the same manner as above. An additional set of hands may be needed to guide material.

BOTTOM CUTTER REPLACEMENT

NOTE: For the steps that follow, first disengage the cutting disc lever.



(Figure 10A) To replace the bottom cutter, other components of the unit must be removed first to gain access to the bottom cutter.



(Figure 10B) Remove gear guard by loosening two hex head cap screws using 7/16" wrench. Pull off gear guard.



(Figure 10C)

Remove the top shaft assembly by first removing the hex cap screws which hold the top cutter lifter bearing **(Figure 10C)** and thrust bearing housing **(Figure 10D)** in place using 7/16" wrench.



(Figure 10D)



(Figure 10E) Slide top shaft assembly out of the frame assembly.

BOTTOM CUTTER REPLACEMENT *(continued from page 5)*



(Figure 10E) Remove bottom cutter support bearing by removing two socket head cap screws holding the bottom cutter support bearing in place. There are two locating pins which align the bottom cutter support bearing to the frame assembly. The pins do not need to be removed, but you may need a non-marking hammer to help ease the bottom cutter support bearing from the frame assembly as the pins fit tightly.



(Figure 10F) Lift bottom cutter out of frame assembly.

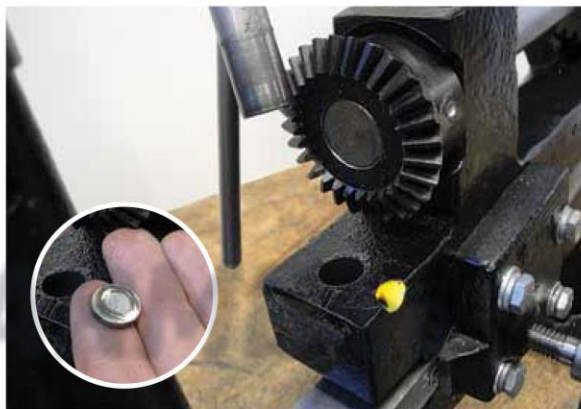

(Figure 10G)

NOTE: Be aware that a bushing is located inside the hole holding the bottom cutter. This bushing should be reused when the bottom cutter is replaced.

TOP CUTTING DISC REPLACEMENT



(Figure 10H) Assembly is the reverse of the previous steps.

NOTE: When assembling the top shaft assembly, the washer assembly for the top cutter lifter bearing must be assembled with a pin which lines up two washers and the top cutter disc lifter bearing. Tighten this bolt so that moderate resistance is felt when engaging and disengaging cutting disc lever.



(Figure 11) Disengage cutting disc lever. Use spanner wrench (included) and place into corresponding holes in top cutting disc. The top cutting disc is loosened by holding spanner wrench and turning the crank handle counter-clockwise. It may be necessary to give the crank handle a sharp blow with the palm of your hand to initially loosen the cutting disc. Place new or sharpened cutting disc onto top shaft and tighten by holding with spanner wrench and turning crank handle clockwise.

NOTE: Figure 11 shows crank direction for loosening top cutting disc.

SHARPENING THE TOP CUTTING DISC FOR NON-METALLIC GASKETS



(Figure 12) Sharpen by holding a small, hand sharpening stone to bevel side of the cutting disc. Slowly turn the hand crank. Then hold the stone to the flat face to remove rolled edges or burrs.

NOTE: Sharpening the top cutting disc for metallic gaskets is not recommended.

CUTTER ADJUSTMENTS

The positions of the cutting discs are pre-set at the factory. However, over time, as cutting discs wear and/or are replaced, adjustments may need to be made to maintain proper operation.

Check the cutting discs to make sure that the cutting edges are sharp, have no nicks or dings, and are concentric. Replace if necessary. Ensure that the discs are tight on their respective shafts by tightening with the spanner wrench. To adjust the cutter refer to the **CUTTER ADJUSTMENT DIAGRAMS** on page 9.

Note: Proper cutter adjustment must proceed in the following order: Top Shaft Assembly End-Play, Clearance, Depth.

Removing Top Shaft Assembly End-Play

Disengage the top cutting disc (A) by rotating the cutting disc lever (H) counter-clockwise. Using 1-5/16" wrench, loosen jam nut (C). Preset thrust bearing (D) to a space of 1/8" with the adjustment pin (included). Tighten the jam nut against thrust bearing housing (G) with 1-5/16" wrench.



(Figure 13) Remove top shaft assembly end-play by unscrewing the outer hex-nut (F) with 9/16" wrench and adjusting the inner hex-nut (E) in, or out. Once end-play is removed (top shaft assembly will not slide back and forth), lock the inner hex-nut in position. Hold the inner hex-nut with a wrench and tighten the outer hex-nut snug against the inner hex-nut, being careful not to change the position of the inner hex-nut. Double check that end-play has been removed. Crank cutter handle to make sure the top shaft assembly has not been adjusted too tight and that it rotates with just slight resistance.

Clearance Adjustment (x axis)

First, set the initial clearance between the bottom cutter (B) and top cutting disc (A). Loosen the jam-nut until the thrust bearing rotates freely. Engage the top cutting disc by slowly rotating the cutting disc lever clockwise, making sure that the top cutting disc lines up adjacent to the bottom cutter. Adjust the thrust bearing in or out as necessary to ensure this alignment using adjustment pin.



(Figure 14) The correct clearance adjustment for the cutter is achieved by placing a piece of 0.003" shim stock between the top cutting disc and the bottom cutter and adjusting until there is slight resistance on the shim stock.

Note: When making the clearance adjustment, be sure the outermost edge (diameter) of the top cutting disc does not interfere with the bottom cutter when engaging cutting disc lever, or damage will occur to the top cutting disc edge.

Depth Adjustment (y axis)



(Figure 15) The depth of cut is adjusted by screwing the depth adjustment screw (I) in, or out, until 1/32" depth of cut is achieved. Lock adjustment screw in place with locking nut using 7/16" wrench.

Note: The correct depth adjustment allows the top cutting disc to be fully lowered adjacent to the bottom cutter without mechanical interference.

CUTTER ADJUSTMENT DIAGRAMS

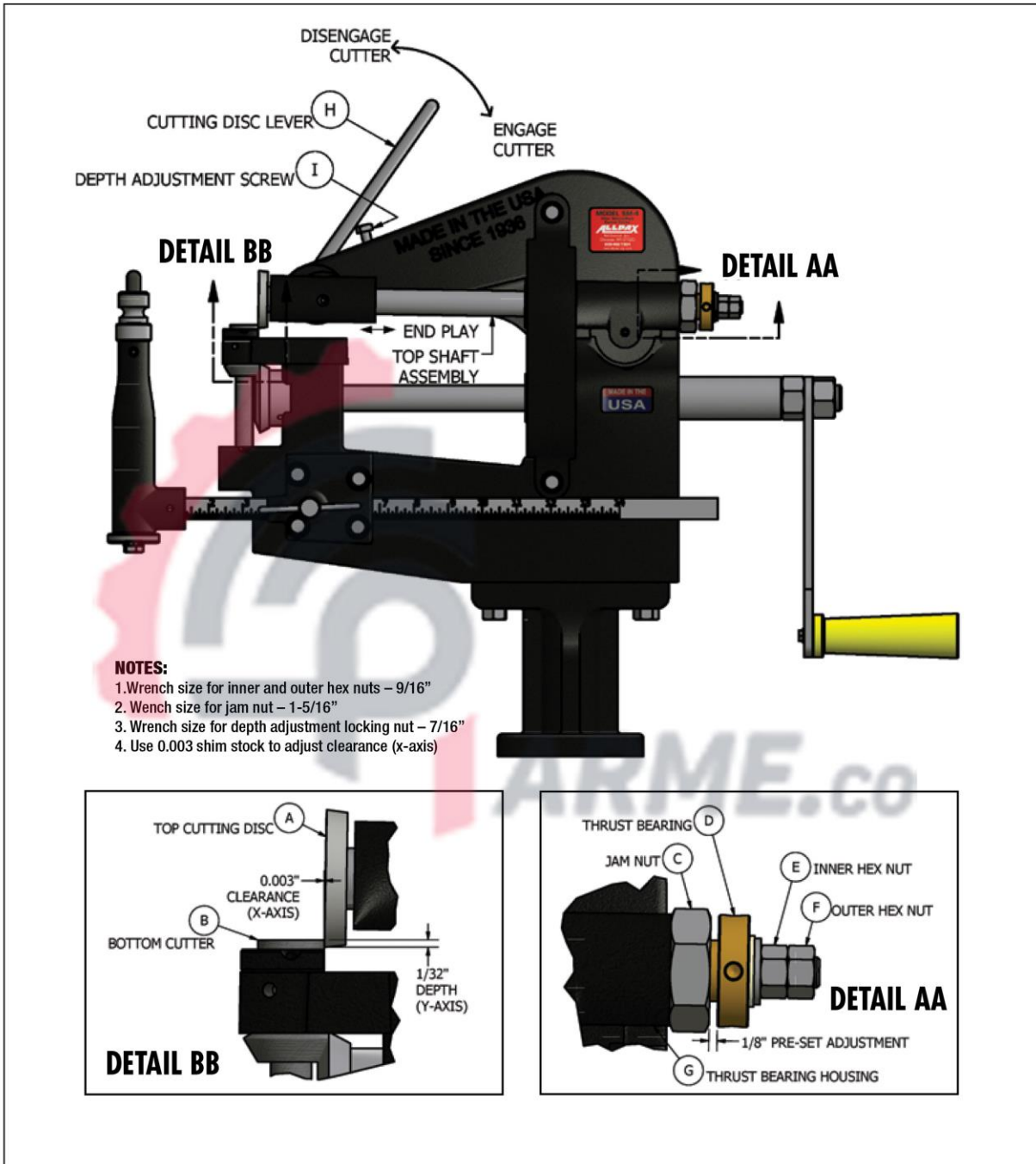

(Figure 16)

GENERAL MAINTENANCE AND LUBRICATION



(Figure 17) The Model SM4 is pre-lubricated at the factory. Like any piece of precision machinery, regular cleaning and lubrication of all gears, and moving parts is recommended. Light machine oil should periodically be applied to points A, B, C, D, E, F, G, and H. Replace worn parts as necessary.

**TO SEE THE SM4 IN ACTION
SCAN THE QR CODE BELOW**



REPLACEMENT PARTS

Replacement parts are available from your local distributor or direct from the factory. Contact our Customer Service Department for pricing information.

ITEM	QTY	PART NO	DESCRIPTION
1	1	M413	STANDARD SCALE BAR (2"-28")
2	1	M413A	MEDIUM SCALE BAR (28"-54")
3	1	M413B	LONG SCALE BAR (54"-80")
4	1	M420	SCALE BAR KNURLED NUT
5	1	M414	BOTTOM CUTTER (GEARED)
6	1	M415A	TOP CUTTING DISC FOR METAL
7	1	M312	TOP CUTTING DISC FOR NON-METAL

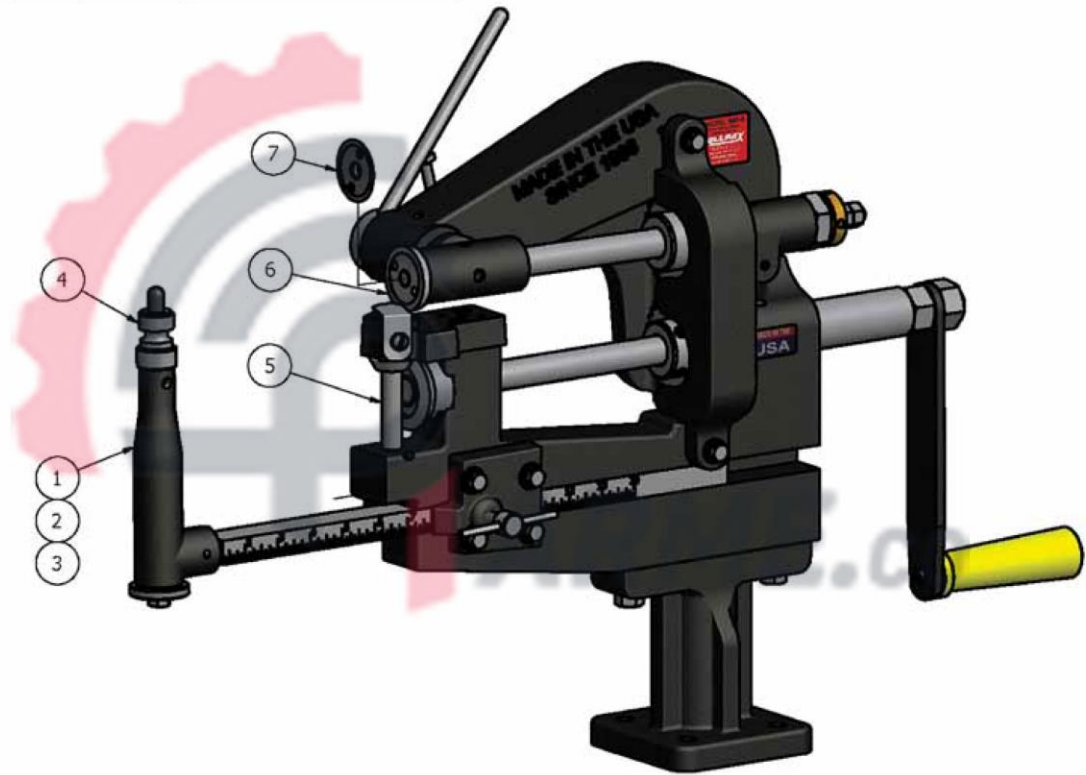

(Figure 18)

HOLLOW PUNCH TOOLS & HAMMERS

Also available from Allpax Gasket Cutter Systems

Cut perfect bolt holes, washers & sealing rings.

Select the desired diameter cutting head, snap onto handle, position on top of gasket material, and strike!

HOLLOW PUNCH TOOL KITS

- Available in Standard (1/8" to 2" OD) and Metric (2mm to 50mm OD) sizes
- Convenient 11, 16 and 27 piece kits

HOLLOW PUNCH TOOLS

- Patented locking system for quick and easy interchange of cutting heads
- Unique design cuts holes (single diameter), or cuts rings (dual diameter) in one operation
- Hardened steel cutting heads stay sharp

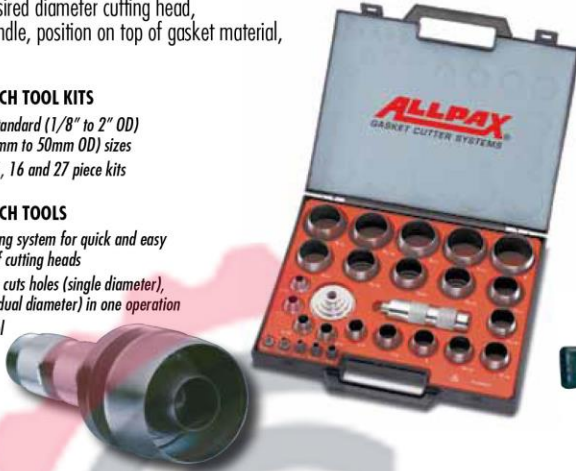

Hollow Punch Tool Kit (27 piece kit shown)

DEAD BLOW HAMMERS

- Heavy shot-loaded head reduces rebound & absorbs impact
- Soft face eliminates marring; reduces noise
- Tapered, textured handle ensures superior grip
- Available in 5 sizes; 1 to 3 lbs.



ALLPAX
GASKET CUTTER SYSTEMS

54 Second Avenue
Chicopee, MA 01020
Phone (413) 594-4400
Toll Free (800) 482-7324
Fax (413) 594-4884
www.guardaircorp.com • info@guardaircorp.com



تامین و تجهیز ابزار دقیق آرمه

Armecompany.com

09125795160



A DIVISION OF

GUARDAIR
CORPORATION