

AFF110 FLANGE FACER TOOL

Facing Range: 1 – 13.7" (25.4-350mm)

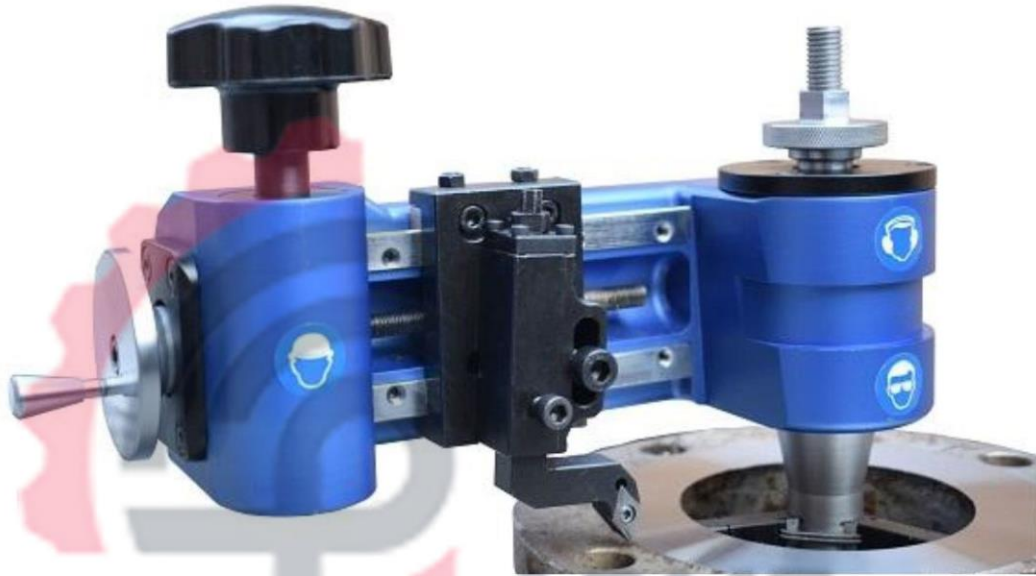

Facing diameter:25.4-350mm

Mounting range:25.4-252mm

NW/GW: 7/11KG

Tool post travel: 70mm

2 off Interchangeable lead screws : 1 off for smooth finish

1 off for stock finish



تامین و تجهیز ابزار دقیق آرمه

Armecompany.com

09125795160

It allows any technician to recondition RF/FF or lens-ring joint flanges and other gasket seating in situ, which makes pipe flanges resurface-able in a safe and convenient way.

AFF110 is a very efficient tool for service or repair workshop but also for piping construction companies and vessel manufacturers or oil & gas industry .

Technical Specification		
Facing Diameter:		
Min Facing Diameter	1 inches	25.4 mm
Max Facing Diameter	13.78 inches	350mm
ID Mounting Diameter		
Min I.D. Mount	1 inches	25.4 mm
Max I.D. Mount	10 inches	252 mm
Stroke:		
Tool Feed Stroke	2.76 inches	70 mm
Tool Post Swivel Angle	+ / - 30°	
Overall length	12.5 inches	+/- 320mm
Height from flange face upwards	8 inches	+/- 200mm
Minimum swing diameter	18 inches	457.2mm
Approximately Operational Weight	15.43 lbs	7 kg
Approximately Shipping Weight	24 lbs	11 kg
Approximately Shipping Dimensions Length x Width x Height	7.8 x 11.8 x 15.7 inches	200 x 300 x 400 mm

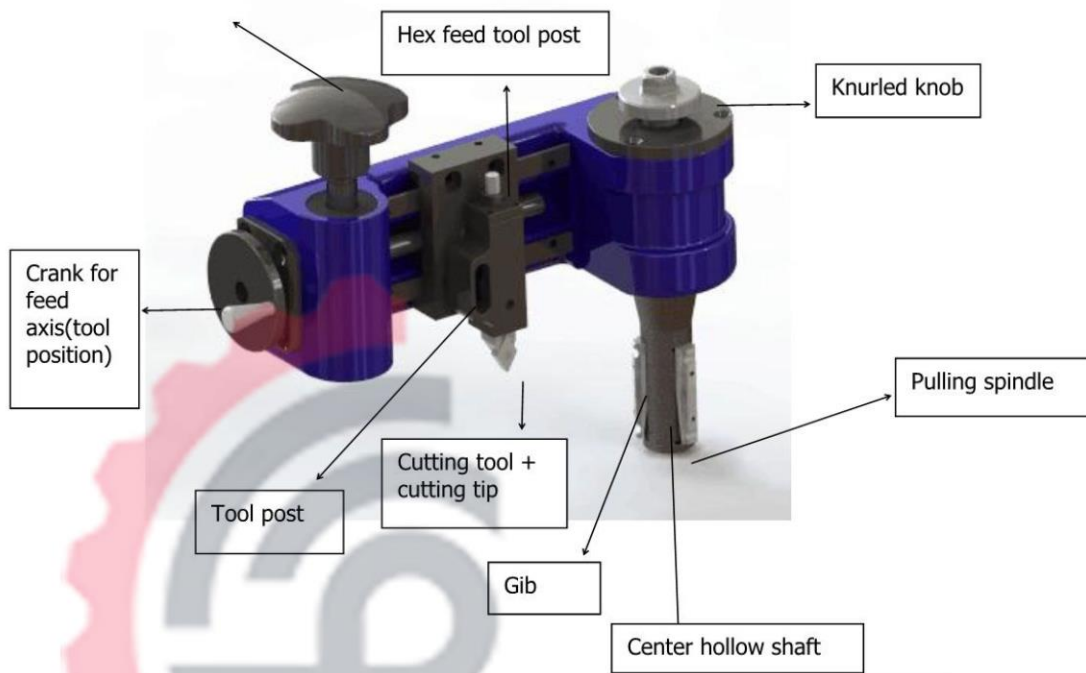

AFF 110 Flange Face Tools Dimension

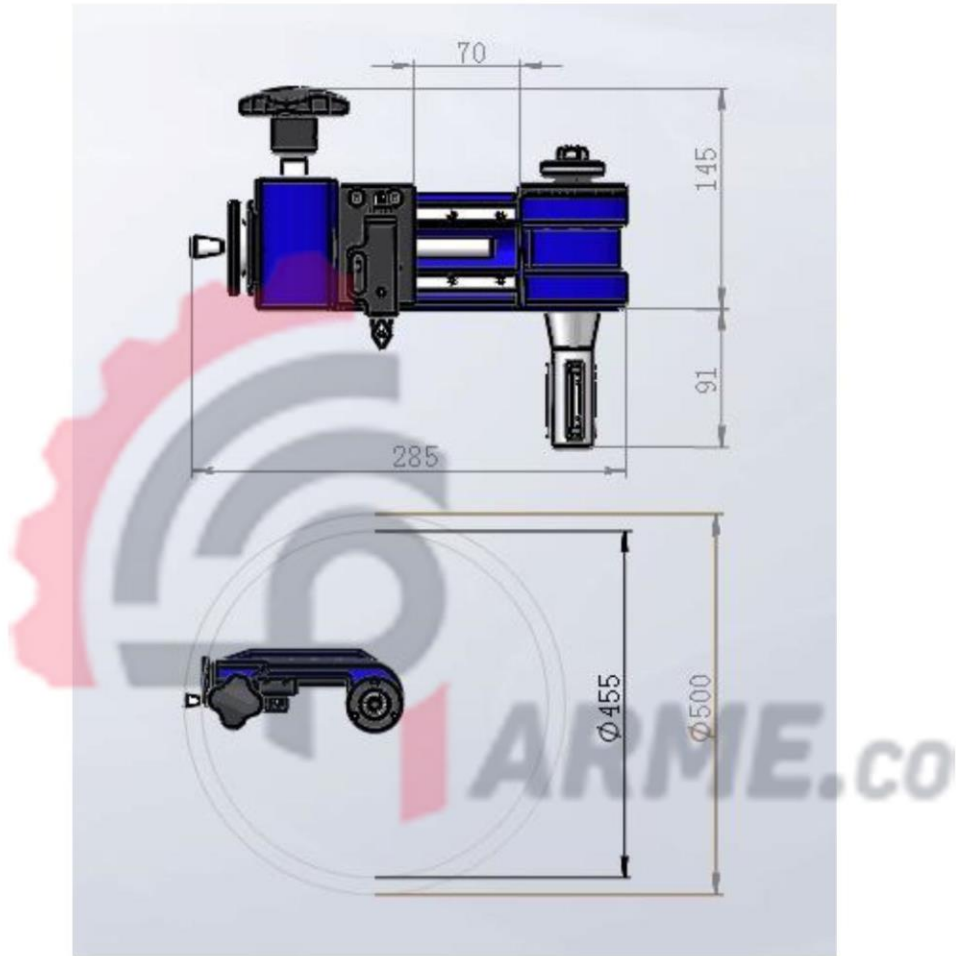

AFF 110 Flange Face Tool Packing list(Delivery consist of)

No	Items	Quantity
1	Primary machine	1 set
2	Feed rod and nut	2 set

3	Gib 1	3 pcs
4	Gib 2	3 pcs
5	5mm Block	3 pcs
6	10mm Block	3 pcs
7	20mm Block	6 pcs
8	50mm Block	3 pcs
9	100mm Block	3 pcs
10	Cutter head	1 set
11	Cutter	1 pcs
12	Cutting tool	3 units
13	Screw	4 pcs
14	Wrench	1 set
15	Allen wrench	3 pcs
16	Rubber hammer	1 unit
17	Tension spring	2 pcs
18	Operation Manual	1 set
19	Packing Box	1 set

This easy to operated hand held flange face tool, allows any technician to recondition RF/FF and other gasket seating in Situ.

AFF110 ON SITE APPLICATION





تامین و تجهیز ابزار دقیق آرمه

Armecompany.com

09125795160