

# TENTEC COMPACT 8 SUBSEA BOLT TENSIONERS

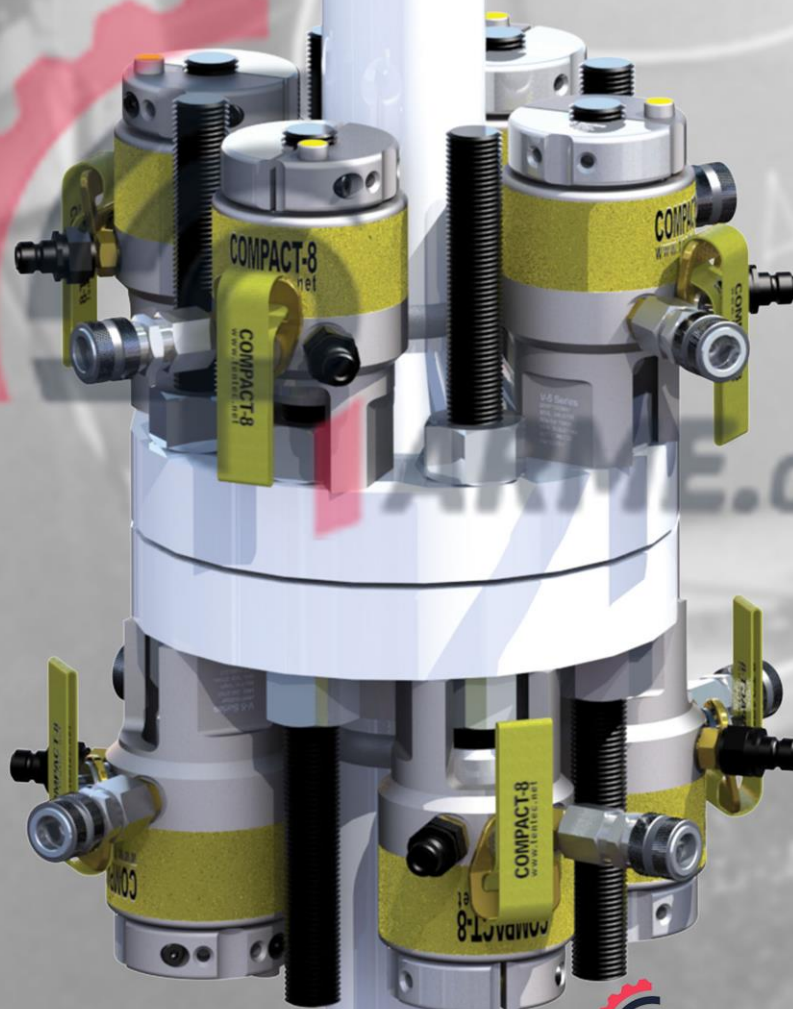

The worldwide standard for subsea bolt tensioning tools.  
8 tensioners capable of bolt tightening over 400  
standard flanges.

*Atlas Copco*



تامین و تجهیز ابزار دقیق آرمه

Armecompany.com

09125795160

# TENTEC COMPACT 8 SUBSEA BOLT TENSIONERS

## Main Features and Benefits

The COMPACT-8 range of subsea bolt tensioning tools brings a new generation of bolting solutions.

Comprising just 8 bolt tensioning tools, the COMPACT-8 series is capable of tensioning most standard flanges including most of the newer Vector SPO\* Compact flanges. The COMPACT-8 series is made from high strength stainless steel which greatly reduces maintenance work to a minimum after subsea use.

Tentec subsea bolt tensioning tools have been used in the UK North sea since 1991 and have a proven reliability and safety record.

- High strength *Stainless Steel* material, minimises maintenance work after usage.
- 30mm ram stroke available.
- Compact size for maximum usability on Vector\* SPO Compact flanges.
- Quick fitting split reaction nuts available on all models.
- High quality reliable seals. 1000's of pressure cycles.
- Uses industry standard quick connect couplings.
- Non slip tool surface for easy diver handling.
- Fitted with lifting straps for easy diver handling.
- Twin hydraulic connections for simple hose assembly.

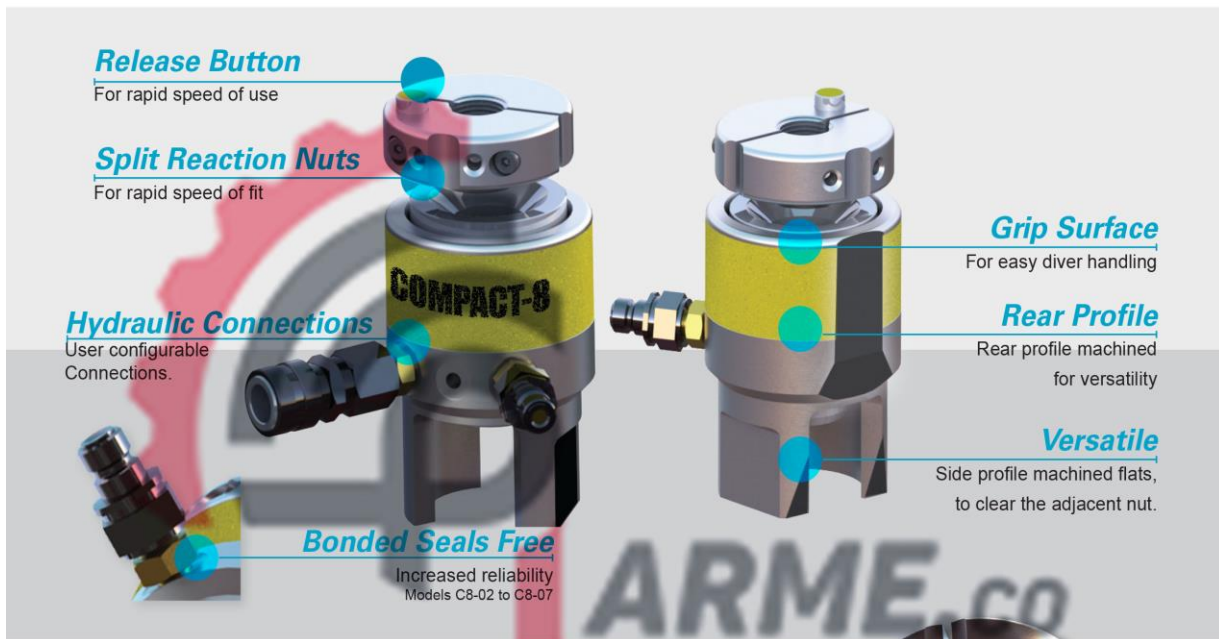

### 8 Tensioners Capable of Tensioning over 400 Standard Flanges.

- SPO\* Vector - Compact Flanges
- ANSI B16.5 Flanges
- ANSI B16.47 Flanges - Series A
- MSS-SP44 Flanges
- API-6A Flanges
- API-17D Flanges

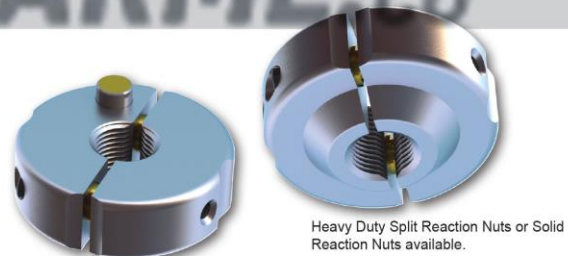

### BOLT TIGHTENING SOLUTIONS

The Compact-8 range of subsea Bolt Tensioning tools can be supplied with quick acting Split Reaction Nuts. The rapid speed of fit ensures the most efficient use of expensive diver time.

\*SPO Vector is a trademark of Vector International Limited. All rights reserved

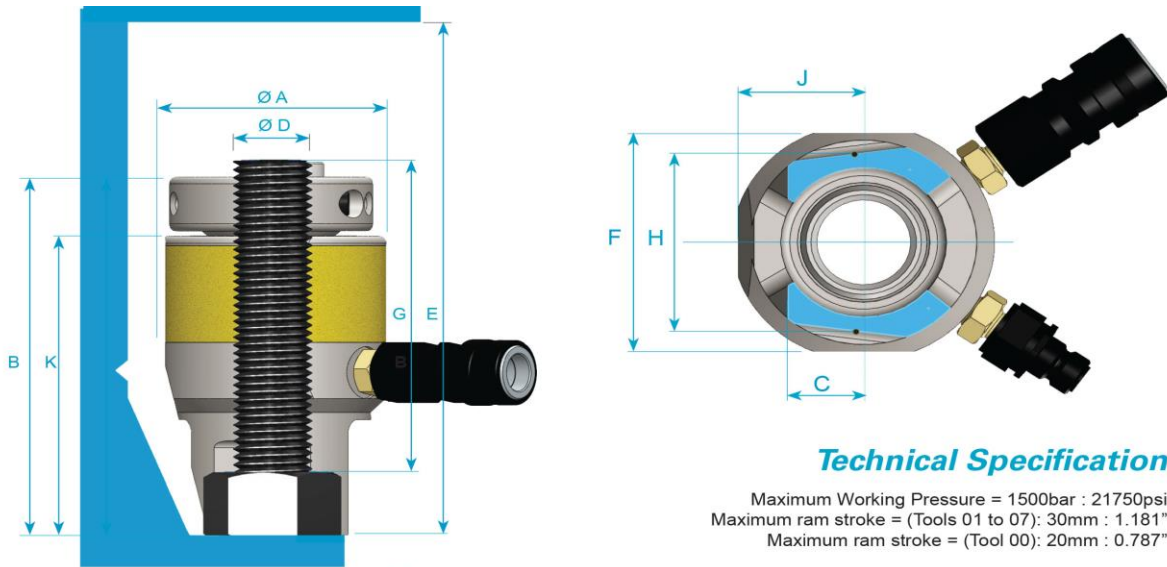

### Technical Specification

Maximum Working Pressure = 1500bar : 21750psi  
 Maximum ram stroke = (Tools 01 to 07): 30mm : 1.181"  
 Maximum ram stroke = (Tool 00): 20mm : 0.787"

### Inch Threads

	Bolt Dia	Thread Pitch	Tool Dia	Effective Side Diameter	Tool Height	Radial Dim'n	Max Initial Bolt Load	Hydraulic Area	Ram Stroke	Extra Stud Length (Inc 3xPitches extra)	Headroom Dimension	Across Flats	Radial Dim'n	Dim'n
	D		A	F	B	C				G	E	H	J	K
	Inch		mm	mm	mm	mm	kN	mm <sup>2</sup>	mm	mm	mm	mm	mm	mm
C8-00	0.75	UNC	66.0	66.0	123	20	190.21	1268.420	20	113.5	214.5	50.2	31.6	97.00
	0.875	UNC	66.0	66.0	123	20	190.21	1268.420	20	110.3	214.5	50.2	31.6	97.00
C8-01	1	8-UN	87.0	87.0	153	25	328.87	2193.020	30	137.1	270.5	65	41.5	127.00
	1.125	8-UN	87.0	87.0	153	25	328.87	2193.020	30	134.0	270.5	65	41.5	127.00
C8-02	1.25	8-UN	104.5	104.5	165	28	514.84	3433.170	30	142.8	286.5	82.5	50.15	135.00
	1.375	8-UN	104.5	104.5	165	28	514.84	3433.170	30	139.6	286.5	82.5	50.15	135.00
C8-03	1.5	8-UN	123.1	118.3	184.5	35	746.70	4979.300	30	155.9	321.5	90	59.1	150.50
	1.625	8-UN	123.1	118.3	184.5	35	746.70	4979.300	30	152.8	321.5	90	59.1	150.50
C8-04	1.75	8-UN	150.0	143.5	210.75	48	1177.31	7850.800	30	175.8	365.0	110	71.7	169.75
	1.875	8-UN	150.0	143.5	210.75	48	1177.31	7850.800	30	172.7	365.0	110	71.7	169.75
C8-05	2	8-UN	150.0	143.5	210.75	48	1177.31	7850.800	30	169.5	365.0	110	71.7	169.75
	2.25	8-UN	182.5	174.3	235.75	59	1904.04	12696.940	30	188.1	393.0	136	87.1	179.75
C8-06	2.5	8-UN	182.5	174.3	235.75	59	1904.04	12696.940	30	181.8	393.0	136	87.1	179.75
	2.75	8-UN	210.0	210.0	259.75	65	2542.11	16951.840	30	199.4	432.0	163.5	105	199.75
C8-07	3	8-UN	210.0	210.0	259.75	65	2542.11	16951.840	30	193.1	432.0	163.5	105	199.75
	3.25	8-UN	258.1	258.1	302.8	85	4059.32	27069.190	30	229.8	492.6	204	129	232.25
C8-07	3.5	8-UN	258.1	258.1	302.8	85	4059.32	27069.190	30	223.4	492.6	204	129	232.25
	3.75	8-UN	258.1	258.1	302.8	85	4059.32	27069.190	30	217.1	492.6	204	129	232.25

### Metric Threads

C8-00	20	2.5	66.0	66.0	123	20	190.21	1268.420	20	110.5	212.5	50.2	31.6	97.00
	22	2.5	66.0	66.0	123	20	190.21	1268.420	20	108.5	212.5	50.2	31.6	97.00
C8-01	24	3	87.0	87.0	153	25	328.87	2193.020	30	138	270	65	41.5	127.00
	27	3	87.0	87.0	153	25	328.87	2193.020	30	135	270	65	41.5	127.00
	30	3.5	87.0	87.0	153	25	328.87	2193.020	30	133.5	271.5	65	41.5	127.00
C8-02	33	3.5	104.5	104.5	165	28	514.84	3433.170	30	142.5	287.5	82.5	50.15	135.00
	36	4	104.5	104.5	165	28	514.84	3433.170	30	141	289	82.5	50.15	135.00
C8-03	39	4	123.1	118.3	184.5	35	746.70	4979.300	30	157.5	324	90	59.1	150.50
	42	4.5	123.1	118.3	184.5	35	746.70	4979.300	30	156	325.5	90	59.1	150.50
C8-04	45	4.5	150.0	143.5	210.8	48	1177.31	7850.800	30	179.25	369	110	71.7	169.75
	48	5	150.0	143.5	210.8	48	1177.31	7850.800	30	177.75	370.5	110	71.7	169.75
	52	5	150.0	143.5	210.8	48	1177.31	7850.800	30	173.75	370.5	110	71.7	169.75
C8-05	56	5.5	182.5	174.3	235.8	59	1904.04	12696.940	30	196.25	400	136	87.1	179.75
	60	5.5	182.5	174.3	235.8	59	1904.04	12696.940	30	192.25	400	136	87.1	179.75
	64	6	182.5	174.3	235.8	59	1904.04	12696.940	30	189.75	401.5	136	87.1	179.75
C8-06	68	6	210.0	210.0	259.8	65	2542.11	16951.840	30	209.75	440.5	163.5	105	199.75
	72	6	210.0	210.0	259.8	65	2542.11	16951.840	30	205.75	440.5	163.5	105	199.75
	76	6	210.0	210.0	259.8	65	2542.11	16951.840	30	201.75	440.5	163.5	105	199.75
C8-07	80	6	258.1	258.1	302.8	85	4059.32	27069.190	30	240.8	501.05	204	129	232.25
	85	6	258.1	258.1	302.8	85	4059.32	27069.190	30	235.8	501.05	204	129	232.25
	90	6	258.1	258.1	302.8	85	4059.32	27069.190	30	230.8	501.05	204	129	232.25
	95	6	258.1	258.1	302.8	85	4059.32	27069.190	30	225.8	501.05	204	129	232.25

Designs and specifications are subject to change without notice or obligation. Read all safety instructions in the manual before usage.

## TENTEC BTS-BOLT TIGHTENING SOFTWARE

Tentec software allows users to manage and rapidly calculate bolt tensioner pressures. Tentec Bolt Load Software has been designed with the philosophy of minimal input, maximum output.

Documentation for multiple bolted joint projects can be created very quickly with minimal operator input. The software package contains data for all standard Vector International compact flanges along with the correct tensioner pressures to apply.

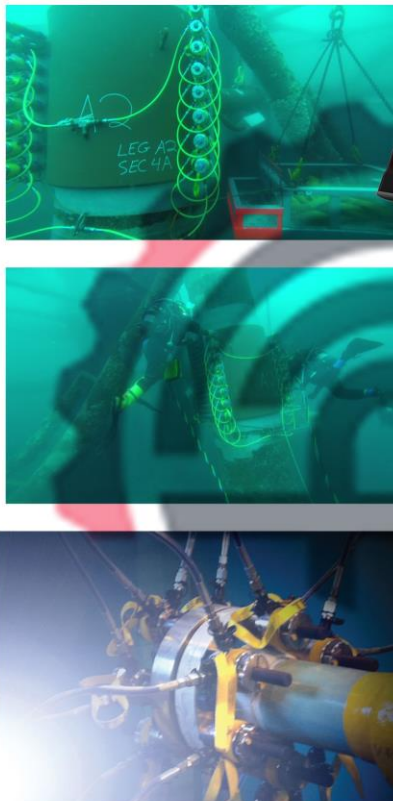

## TENTEC BOLT TIGHTENING SOLUTIONS



تامین و تجهیز ابزار دقیق آرمه  
 Armecompany.com  
 09125795160

COMMITTED TO SUSTAINABLE PRODUCTIVITY

www.bolttighteningsolutions.com

Atlas Copco