

P-Series, Lightweight Hand Pumps

ENERPAC
POWERFUL SOLUTIONS. GLOBAL FORCE.

▼ Shown from top to bottom: P-802, P-842, P-202, P-142



- **Lightweight** and compact design
- **Durable** glass-filled nylon reservoir and nylon encapsulated aluminium pump base for maximum corrosion resistance
- **Two-speed** operation reduces handle strokes by as much as **78% over** single speed pumps
- **Lower handle effort** to minimize operator fatigue
- **Integral 4-way valve** on P-842 for operation of double-acting cylinders
- **Handle lock** and lightweight construction for easy carrying
- **Large oil capacities** to power a wide range of cylinders or tools
- **Non-conductive fiberglass handle** for improved operator safety
- **Internal pressure relief valve** for overload protection.

▼ Cylinder-pump set SCR-254H used to support the construction while monitoring pressure and load with the gauge.



تامین و تجهیز ابزار دقیق آر مه
Armecompany.com
09125795160

Exclusively from Enerpac



Cylinder Matching Chart

For help in selecting the correct hand pump for your application, please refer to the Cylinder Matching Chart located in the 'Yellow Pages'.

Page: 266



Speed Chart

To determine how a specific pump will operate your cylinder, see the Pump-Cylinder Speed Chart in the 'Yellow Pages'.

Page: 273



Tank Kits:

When a return-to-tank port is required, the Tank Kits provide a 7/16"-20 UN port at the rear of the reservoir.

PC-20	Fits P-141, P-142
PC-25	Fits P-202, P-391, P-392



Power Box

Portable tool box with P-392 hand pump, gauge adaptor assembly, hose and RC-, RCS, RSM- or WR-Series cylinder.

Page: 61

Pump Type	Usable Oil Capacity (cm ³)	Model Number	Pressure Rating ²⁾ (bar)		Oil Displacement per Stroke (cm ³)		Max. Handle Effort (kg)
			1 st stage	2 nd stage	1 st stage	2 nd stage	
Single-Speed	327	P-141	-	700	-	0,90	32,7
	901	P-391	-	700	-	2,47	38,6
Two-Speed	327	P-142 ¹⁾	13	700	3,62	0,90	35,4
	901	P-202	13	700	3,62	0,90	28,6
	901	P-392 ¹⁾	13	700	11,26	2,47	42,2
	2540	P-802	27	700	39,33	2,47	43,1
	2540	P-842 ³⁾	27	700	39,33	2,47	43,1

¹⁾ Available as set, see note on next page. P-392 also available in Power Box Set (page 61).

²⁾ Contact Enerpac for applications where operating pressure is less than 10% of pressure rating.

³⁾ P-842 for use with double-acting cylinders

Lightweight Hand Pumps



Pump-Cylinder Sets

All pumps marked with an * are available as **sets** (pump, cylinder, gauge, couplers and hose) for your ordering convenience.

Page: 58

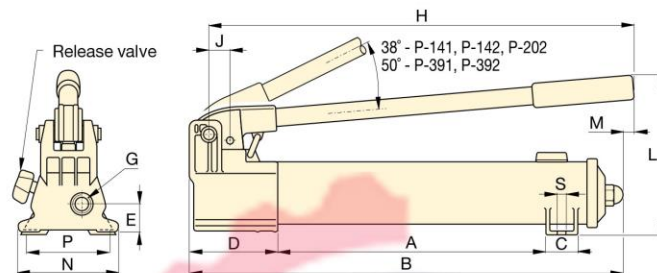

P-141, P-142, P-202, P-391, P-392

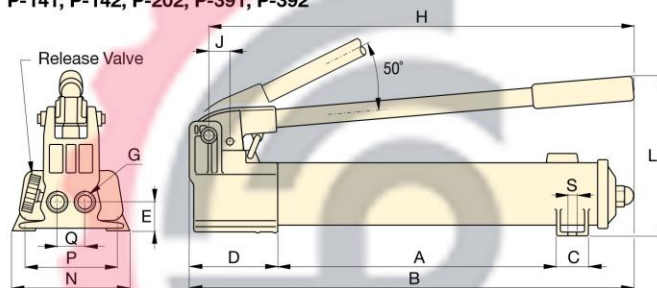

P-802

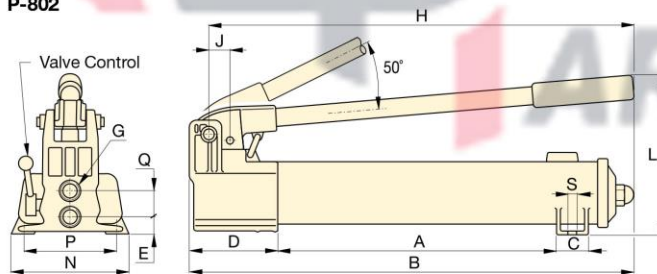

P-842

P Series



Reservoir Capacity:

327 - 2540 cm³

Flow at Rated Pressure:

0,90 - 2,47 cm³/stroke

Operating Pressure:

700 bar



Hoses

Enerpac offers a complete line of high quality hydraulic hoses. To ensure the integrity of your system, specify only genuine Enerpac hydraulic hoses.

Page: 122



GA45GC Gauge Adaptor

Protect yourself from system overloading by simply ordering one part number for a pre-assembled gauge, adaptor block and coupler.

Page: 134



Foot Pump P-392FP

For handsfree operation the lightweight and robust P-392FP Foot Pump is the perfect choice.

Page: 79

Piston Stroke	Dimensions (mm)															Model Number
	(mm)	A	B	C	D	E	G	H	J	L	M	N	P	Q	S	
12,7	185	336	28	85	28	1/4"-18 NPTF	319	19	143	-	95	80	-	7	2,4	P-141
25,4	344	533	36	99	33	3/8"-18 NPTF	522	30	177	16	120	-	-	-	4,1	P-391
12,7	185	336	28	85	28	1/4"-18 NPTF	319	19	143	-	95	80	-	7	2,4	P-142 ¹⁾
12,7	344	509	36	85	28	1/4"-18 NPTF	400	19	144	16	95	-	-	-	3,4	P-202
25,4	344	533	36	99	33	3/8"-18 NPTF	522	30	177	16	120	-	-	-	4,1	P-392 ¹⁾
25,4	337	552	45	133	35	3/8"-18 NPTF	527	30	228	-	181	153	35	10	8,2	P-802
25,4	337	552	45	133	20	3/8"-18 NPTF	527	30	228	-	181	153	36	10	10,0	P-842 ³⁾

P-Series, ULTIMA Steel Hand Pumps

ENERPAC
POWERFUL SOLUTIONS. GLOBAL FORCE.

▼ Shown from left to right: P-77, P-80, P-84, P-801, P-39



- Reduced handle effort and ergonomic grip for less operator fatigue
- Two-speed operation for fast and easy operation (except P-39)
- Vent free reservoir eliminates spills
- Quick grip handle allows for easy transport
- Integral reservoir over-pressurization protection
- All steel construction, chrome plated plunger and wiper system for durable, long lasting performance
- 4-way valving on the P-84 and P-464 for operation of double-acting cylinders.

▼ In the absence of a power supply, the P-80 Hand Pump offers a powerful solution.



The Solution for Tough Jobs



Two Speed Pumps

Recommended for applications where cylinder plunger must advance rapidly to load contact, and applications where greater oil capacities are required, such as multiple cylinder hook-ups.



Foot Pump Conversion Kits

Convert your P-39, P-77, P-80 or P-801 to foot power with the PC-11 Kit. Includes instructions for easy conversion.



GA45GC Gauge Adaptor

Protect yourself from system overloading by simply ordering one part number for a pre-assembled gauge, adaptor block and coupler.

Page: 134



4-Way Control Valve

P-84 and P-464 feature a manual 4-way control valve, designed for use with one double-acting or two single-acting cylinders. For system set-up information:

Page: 268

Pump Type	Usable Oil Capacity (cm ³)	Model Number	Pressure Rating ²⁾ (bar)		Oil Displacement per Stroke (cm ³)		Max. Handle Effort (kg)
			1 st stage	2 nd stage	1 st stage	2 nd stage	
Single	672	P-39	-	700	-	2,46	39
Two-Speed	672	P-77	34	700	16,39	2,46	40
	2200	P-80 ¹⁾	34	700	16,39	2,46	35
	4100	P-801	34	700	16,39	2,46	35
	2200	P-84 ³⁾	34	700	16,39	2,46	35
	7423	P-462	14	700	126,20	4,75	49
	7423	P-464 ³⁾	14	700	126,20	4,75	49

¹⁾ Available as a set, see note on next page.

²⁾ Contact Enerpac for applications where operating pressure is less than 10% of pressure rating.

³⁾ P84, P-464 is for use with double-acting cylinders.

ULTIMA Steel Hand Pumps

i **Speed Chart**
To determine how a specific pump will operate your cylinder, see the Pump-Cylinder Speed Chart in the 'Yellow Pages'.

Page: 273

P Series



Reservoir Capacity:
672 - 7423 cm³

Flow at Rated Pressure:
2,46 - 4,75 cm³/stroke

Maximum Operating Pressure:
700 bar

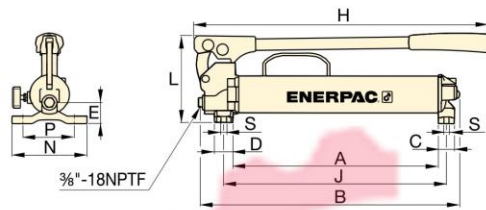

P-39, P-77

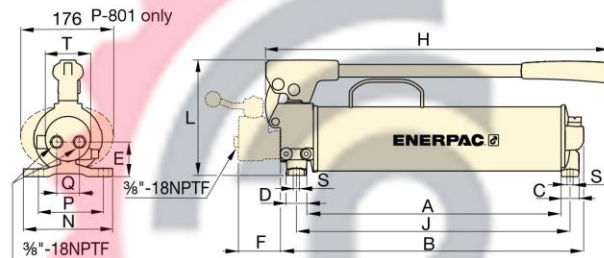

P-80, P-801, P-84

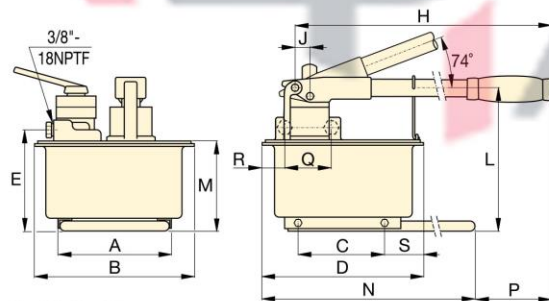

P-462, P-464



Extra Capacity Hand Pumps

P-462 and P-464 feature extra large reservoirs and high first-stage flow rate.

These pumps are ideally suited for powering high-capacity cylinders.

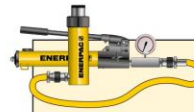

Pump-Cylinder Sets

The P-80 is also available as set (pump, cylinder, gauge, couplers and hose) for your ordering convenience.

Page: 58



Cylinder Matching Chart

For help in selecting the correct hand pump for your application, please refer to the Cylinder Matching Chart located in the 'Yellow Pages'.

Page: 266

Piston Stroke	Dimensions (mm)																Model Number	
	(mm)	A	B	C	D	E	F	H	J	L	M	N	P	Q	R	S		T
25,4	383	480	30	35	37	-	550	416	163	-	140	111	-	-	8,4	-	6,2	P-39
25,4	391	487	30	35	47	-	550	424	163	-	140	111	-	-	8,4	-	7,1	P-77
25,4	428	511	30	35	55	-	579	460	195	-	150	121	42	-	8,4	74	10,7	P-80 ¹⁾
25,4	428	511	30	35	55	-	579	460	195	-	150	121	42	-	8,4	74	14,1	P-801
25,4	428	510	30	35	55	70	579	460	195	-	150	121	38	-	8,4	74	11,8	P-84 ³⁾
38,1	210	308	163	320	195	-	671	25	270	175	650	92	-	-	80	-	27,7	P-462
38,1	210	308	163	320	195	-	671	25	270	175	650	92	89	68	80	-	27,7	P-464 ³⁾

P-Series, Low Pressure Hand Pumps

ENERPAC
POWERFUL SOLUTIONS. GLOBAL FORCE.

▼ Shown from left to right: P-25, P-51, P-18



When Less Than 700 Bar is All You Need



GA45GC Gauge Adaptor

Protect yourself from system overloading by simply ordering one part number for a pre-assembled gauge, adaptor block and coupler.

Page: 134



Hoses

Enerpac offers a complete line of high quality hydraulic hoses. To ensure the integrity of your system, specify only genuine Enerpac hydraulic hoses.

Page: 122

- P-25 and P-50 pump oil in both forward and reverse handle movement improving overall efficiency, ideal when mounting space is restricted
- External load-release valve
- Internal pressure-relief valve for overload protection
- For use with single-acting cylinders and tools.

▼ P-18 hand pump used for locking the rotating table for marble polishing.



Pump Type	Usable Oil Capacity (cm ³)	Model Number *	Pressure Rating (bar)	Oil Displacement per Stroke (cm ³)	Max. Handle Effort (kg)
Single-Speed	360	P-18	200	2,46	16
	3277	P-25	175	9,50	27
	3277	P-50	350	4,75	27
	819	P-51	200	4,10	27

* For use with single-acting cylinders and tools

Low Pressure Hand Pumps

P Series



Reservoir Capacity:
360 - 3277 cm³

Flow at Rated Pressure:
2,46 - 9,50 cm³/stroke

Maximum Operating Pressure:
175 - 350 bar

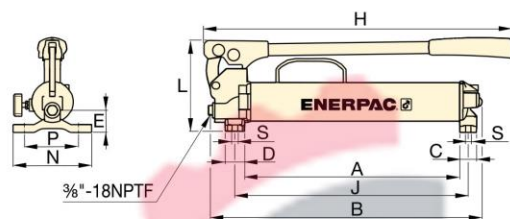

P-18

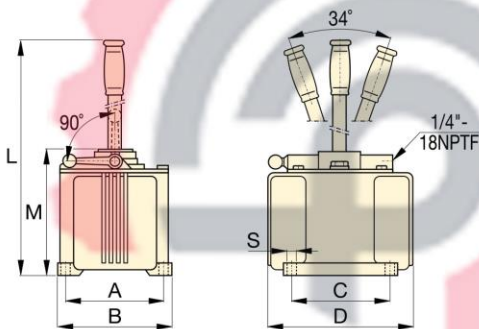

P-25, P-50

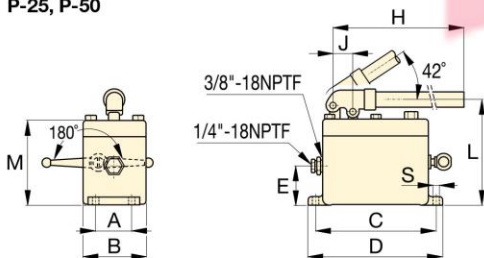

P-51



MP-Series Multifluid Hand Pumps

Corrosion resistant hand pumps for low pressure filling and high pressure testing applications, suitable for a wide range of fluids.

Page: 78

▼ P-51 hand pumps used with RC-series cylinders to keep wooden layers under pressure during lamination of plates.



Piston Stroke	Dimensions (mm)												Model Number *
	(mm)	A	B	C	D	E	H	J	L	M	N	S	
25,4	221	316	30	35	37	385	254	163	-	140	8,4	5,0	P-18
38,1	152	173	152	240	-	-	-	684	200	-	10	16,3	P-25
38,1	152	173	152	240	-	-	-	684	200	-	10	16,8	P-50
25,4	52	92	181	200	57	610	29	160	129	-	9	5,4	P-51

MP-Series, Multifluid Hand Pumps

ENERPAC
POWERFUL SOLUTIONS. GLOBAL FORCE.

▼ Shown: MP-110



- Superior corrosion resistance
- Standard Nitrile seals – can be used for a wide range of fluids such as demineralised water, oil/water emulsions, waterglycols, mineral oils
- Two speed pumps up to 1000 bar
- Buna Nitrile seals can be exchanged with optional EPDM seal for use with Skydrol or brake fluids
- Impregnated aluminium anodized pump housing with stainless steel internal pumping components
- Externally adjustable pressure relief valve
- 1/4" NPTF gauge port
- For use with single-acting cylinders and tools.

MP Series

Flow at Rated Pressure:

1,6 - 20,6 cm³/stroke

Maximum Operating Pressure:

110 - 1000 bar



Optional Reservoir Kit

Includes 10 litres tank with skid frame, top plate with reservoir seal, suction pipe and mounting bolts.

Useable oil capacity is 7,4 litres. Order model number: **MP-10T**.



Stainless Steel Hand Pump

Also available as stainless steel hand pump, model number **11-400**.

Page: 80

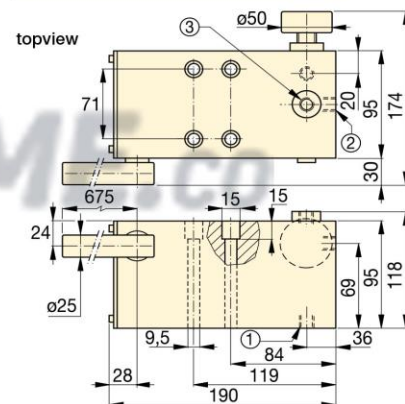

MP-110, 350, 700, 1000

- ① Suction / Tank return port 3/8"-18 NPTF
- ② Pressure port 3/8"-18 NPTF
- ③ Gauge port 1/4"-18 NPTF

Pump Type	Usable Oil Capacity * (cm ³)	Model Number **	Pressure Rating (bar)		Oil Displacement per Stroke (cm ³)		Max. Handle Effort (kg)	Piston Stroke (mm)	Piston Stroke (kg)
			1st stage	2nd stage	1st stage	2nd stage			
Two Speed	*	MP-110	35	110	52,6	20,60	45	27,1	6,6
	*	MP-350	35	350	52,6	7,15	45	27,1	6,6
	*	MP-700	35	700	52,6	2,63	45	27,1	6,6
	*	MP-1000	35	1000	52,6	1,60	45	27,1	6,6

* MP-Pump includes 1,5 mm thick gasket for reservoir mounting. MP-Series pumps requires the use of an external reservoir.
** MP-Series pumps are for use with single-acting cylinders and tools.

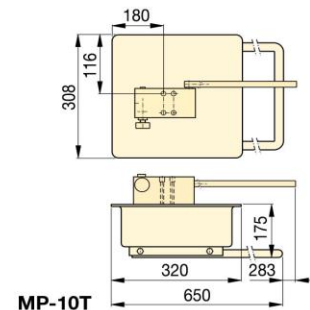

Lightweight Hydraulic Foot Pump

▼ Shown: P-392FP



- Robust, durable and compact
 - Steel frame for maximum stability
 - Steel pumping handle
 - Aluminium reservoir
- Foot pedal lock and lightweight construction for easy carrying
- Two-speed operation reduces foot pedal strokes
- Large foot-pad release valve for controlling load descent
- Internal pressure relief valve for overload protection.

P Series



Reservoir Capacity:
492 cm³

Flow at Rated Pressure:
2,47 cm³/stroke

Maximum Operating Pressure:
700 bar



Pump-Cylinder Sets

The P-392FP is available as **set** (pump, cylinder, gauge, couplers and hose) for your ordering convenience.

Page: 58



Hoses

Enerpac offers a complete line of high quality hydraulic hoses. To ensure the integrity of your system, specify only genuine Enerpac hydraulic hoses.

Page: 122

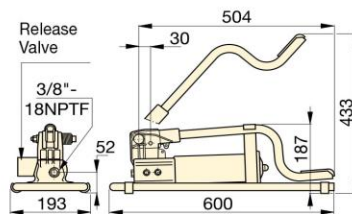

Usable Oil Capacity (cm ³)	Model Number	Pressure Rating (bar)		Oil Displacement per Stroke (cm ³)		Max. Handle Effort (kg)	Piston Stroke (mm)	Weight (kg)
		1st stage	2nd stage	1st stage	2nd stage			
492	P-392FP *	15	700	11,26	2,47	42	25,4	7,0

* Available as set, see note on this page.

▼ P-392FP offers the advantage of hands free operation to handle and control the tool or cylinder.



Ultra-High Pressure Hand Pumps



▼ Shown from left to right: 11-100, P-2282



Ultra-High Pressure up to 2800 bar



2-Way Shut-Off Valve Model Nr. 72-750

For 2800 bar applications requiring a shut-off valve or gauge snubber.

Made of 318 Stainless Steel and utilizing .38 inch cone fittings, it is the perfect selection for use with your ultra-high pressure hand pump.



Test System Gauges

Ideal for monitoring pressure in your hydraulic circuit.

Test System Gauges, such as the **T6010L**, are available with cone threads or NPTF threads and a variety of pressure ranges.

Page: 132

- Two-speed operation on the P-2282 allows for faster fill operation, reducing cycle times for many testing applications
- 303 Stainless steel construction on the 11-100 and 11-400 models enable use with many different fluids, such as distilled water, diesters, silicones, soluble oils and petroleum
- Large release knob for improved control of pressure release
- Outlet ports are 3/4"-16 cone for 2800 bar rating
- Ultra-high pressure fittings feature all stainless steel construction except adaptor 41-366 which features nickel plated carbon steel construction.

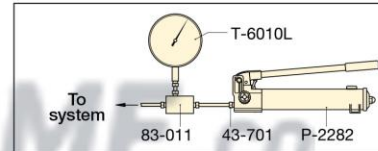

▲ Typical Test System

Cone Seal

Stainless Steel High Pressure fittings seal on a 'cone' surface and do not require pipe sealer. The Gland Nut holds the sleeve and tubing tight against the cone surface to provide a 2800 bar seal.

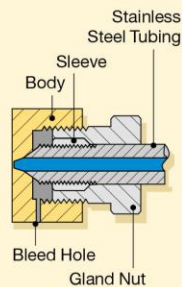

Pump Type	Usable Oil Capacity (cm ³)	Model Number	Pressure Rating * (bar)		Oil Displacement per Stroke (cm ³)		Max. Handle Effort (kg)
			1 st stage	2 nd stage	1 st stage	2 nd stage	
Two-Speed	983	P-2282	13	2800	16,22	0,61	48,1
Single-Speed	737	11-100	-	700	-	2,49	54,4
	737	11-400	-	2800	-	0,62	54,4

* Contact Enerpac for applications where operating pressure is less than 10% of operating pressure.

Ultra-High Pressure Hand Pumps

▼ Optional Ultra-High Pressure Fittings and Tubings

Description	Connection	Model Nr.
2800 bar		
Gland Nut Plug	.38" cone	43-001
Elbow	.38" cone	43-200
Tee	.38" cone	43-300
Gauge Tee	.38" cone side/ .25" cone gauge port	43-301
Gauge Adaptor	.38" cone side/ .25" cone gauge port	83-011
Coupling	.38" cone	43-400
Cross	.38" cone	43-600
Gland Nut with Sleeve	.38" cone	43-701
Gauge Connector	.25" cone	43-704
Tubing	100 mm tube, O.D. .38" * 200 mm tube, O.D. .38" * 300 mm tube, O.D. .38" *	45-116 45-126 45-136
700 bar only		
Adaptor	.38" F cone to 1/4" M NPTF .38" F cone to 3/8" M NPTF	41-146 41-166
Adaptor	.38" F cone to 1/4" F NPTF .38" F cone to 3/8" F NPTF	41-246 41-266
Adaptor	.38" M cone to 3/8" F NPTF	41-366

Note: .25" cone fittings use 9/16"-18 threads, 3/8" cone fittings use 3/4"-16 threads.
* Actual tubing lengths are 19 mm less than nominal size shown. These dimensions make distance between centers of valves and fittings multiples of 100 mm spaces.

P 11 Series



Reservoir Capacity:
737 - 983 cm³

Flow at Rated Pressure:
0,61 - 2,49 cm³/stroke

Maximum Operating Pressure:
700 - 2800 bar



Ultra-High Pressure pumps DO NOT have an internal safety pressure relief valve.



Stainless Steel Construction
Ultra-high Pressure Fittings feature all stainless steel construction except adaptor 41-366, which features nickel plated carbon steel construction.

11-100
11-400

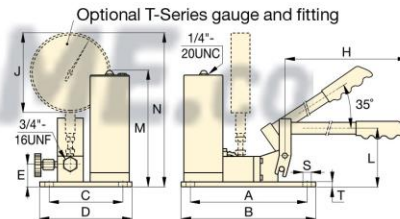

P-2282

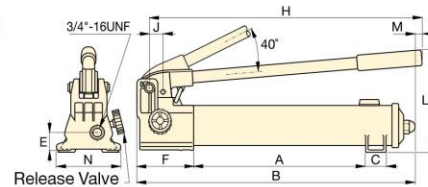

Piston Stroke (mm)	Dimensions (mm)													Model Number	
	A	B	C	D	E	F	H	J	L	M	N	S	T		
25,4	344	558	35	-	31	133	527	29	228	7	120	-	-	6,4	P-2282
19,8	240	266	151	177	45	-	635	162	114	237	314	7	9	10,0	11-100
19,8	240	266	151	177	45	-	635	162	114	237	314	7	9	10,0	11-400

Extreme Environment Products

ENERPAC 
POWERFUL SOLUTIONS. GLOBAL FORCE.

▼ From left to right: P-142ALSS, P-392ALSS, V-152NV, V-66NV, RC-256NV, RC-106NV, RC-53NV



RC, P, V Series

Cylinder Capacity:
5 - 25 ton

Stroke:
51 - 156 mm

Maximum Operating Pressure:
700 bar



Applications

For use in wet environments such as food processing, pulp and paper, mining, construction and applications in high temperature or in welding areas.

- Corrosion resistant, nickel-plated valves and cylinders
- Stainless steel pump inserts will not corrode
- Viton® Seals provide heat and chemical resistance
- Anodized aluminum pump reservoirs and plastic encapsulated pump bodies resist wet environments
- Two-speed operation reduces pump handle strokes 78% compared to single-speed pumps
- Pump handles lock for easy carrying.



Multifluid Hand Pumps

MP-Series corrosion resistant hand pumps for low pressure filling and high pressure testing applications, suitable for a wide range of fluids.







Page: 78



تامین و تجهیز ابزار دقیق آرمه

Armecompany.com

09125795160

	Cylinder Capacity	Stroke	Model Number *	Oil Capacity	Pressure Rating	Collapsed Height	Extended Height	Outside Diameter	
	ton (kN)	(mm)		(cm ³)	(bar)	(mm)	(mm)	(mm)	(kg)
	5 (45)	76	RC-53NV	50	700	165	241	38	1,5
	10 (101)	51	RC-102NV	78	700	121	175	57	2,3
	10 (101)	156	RC-106NV	225	700	247	403	57	4,4
25 (232)	156	RC-256NV	528	700	273	431	85	10,0	
	Pump Type	Oil Capacity	Model Number *	Pressure Rating	Oil Displacement per Stroke	Port Dimension	Piston Stroke		
		(cm ³)		(bar)	(cm ³)	(NPTF)	(mm)	(kg)	
	Two Speed	327	P-142ALSS	14 / 700	3,62 / 0,90	1/4"-18	12,7	2,0	
	901	P-392ALSS	14 / 700	11,26 / 2,47	3/8"-18	25,4	4,1		
	Valve Type	Model Number *	Function				Pressure Rating (bar)		
	Manual Check Valve	V-66NV *	Load holding with cylinders				700	1,8	
	Pressure Relief Valve	V-152NV *	Limits system pressure, ± 3% repeatability				55-700	1,6	

* For cylinder details see pages 7-9; for pump details see pages 72-73; for valve details see pages 136-137.